

REVISIONS

ZONE	REV.	DESCRIPTION	DATE	APPROVED
ALL	PT-1	PROTOTYPE 1	04/14/2017	RVC
ALL	PT-2	PROTOTYPE 2	06/01/2017	RVC
ALL	IR	INITIAL RELEASE FOR PRODUCTION	05/21/2018	RVC
ALL	A	ECO 19-001	03/25/2019	RVC
ALL	B	ECO 20-001	03/30/2020	RVC

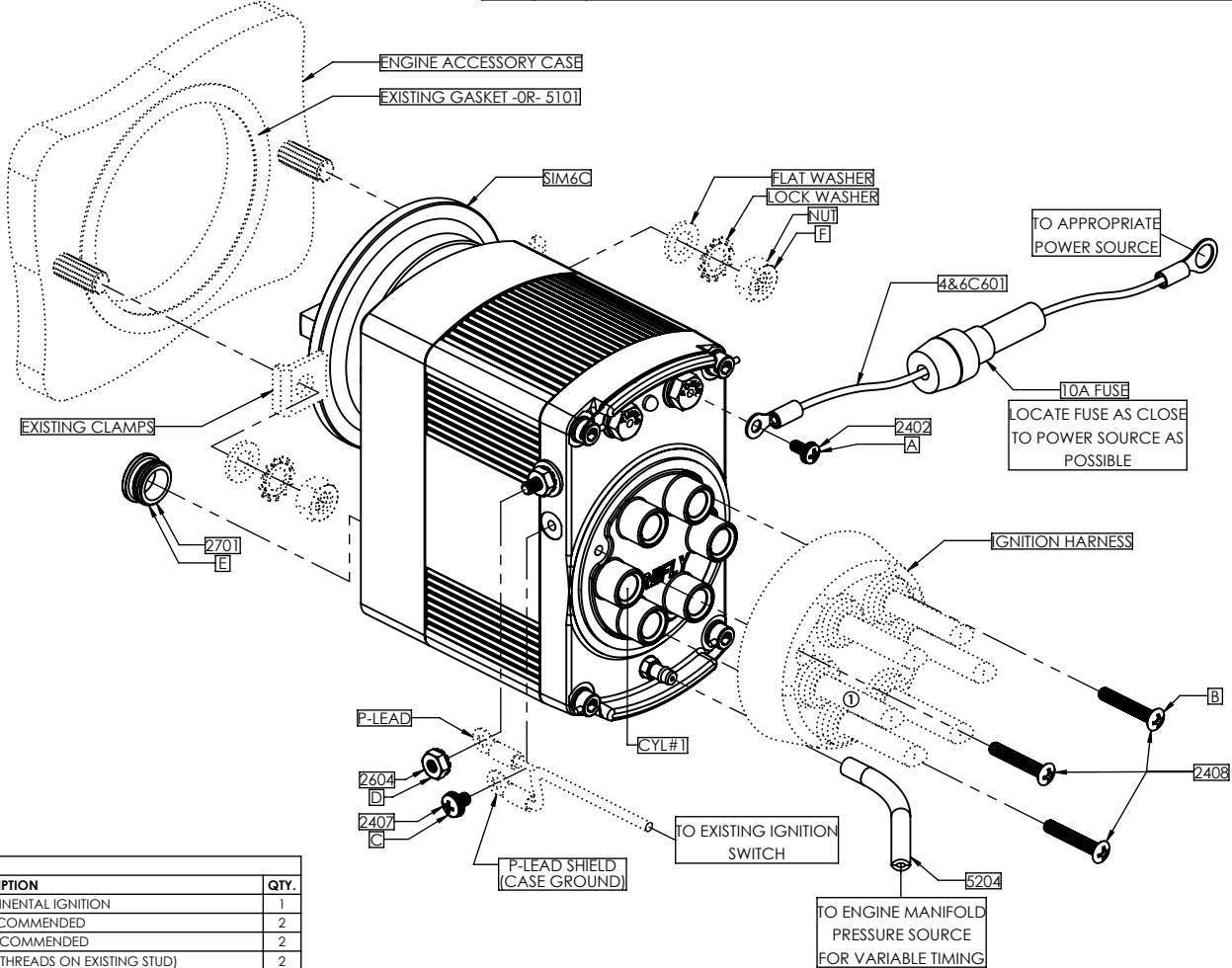

SOURCE TABLE

PART #	TYPE	DESCRIPTION	QTY.
SIM6C	PROPRIETARY	6 CYLINDER CONTINENTAL IGNITION	1
FLAT WASHER	EXISTING	AN930-516 RECOMMENDED	2
LOCK WASHER	EXISTING	MS35335-34 RECOMMENDED	2
NUT	EXISTING	5/16 NUT (-16 OR -24 MATCH THREADS ON EXISTING STUD)	2
4&6C601	PROPRIETARY	POWER WIRE	1
2402	COMMERCIAL	#6-32x5/16" PAN HEAD PHILLIPS MACHINE SCREW W/ INTERNAL TOOTH LOCK WASHER	1
IGNITION HARNESS	FAA-APPROVED	"SLICK STYLE" IGNITION HARNESS, FAA-APPROVED FOR SPECIFIC AIRFRAME AND/OR ENGINE APPLICATION (REFER TO IPC). CONFIRM AIRWORTHINESS IN ACCORDANCE W/ OEM SPECIFICATIONS IF RE-USING EXISTING HARNESS.	1
2408	COMMERCIAL	#8-32x1" OVAL HEAD PHILLIPS MACHINE SCREW	3
5204	COMMERCIAL	Ø 1/8 x Ø 1/4" x 24" VITON TUBING	1
P-LEAD	EXISTING	EXISTING AIRCRAFT P-LEAD & SHIELD (FROM COCKPIT IGNITION SWITCH)	1
2407	COMMERCIAL	#8-32x1/4" PAN HEAD PHILLIPS MACHINE SCREW W/ INTERNAL TOOTH LOCK WASHER	1
2604	COMMERCIAL	#8-32 HEX NUT W/ EXTERNAL TOOTH LOCK WASHER	1
2701	COMMERCIAL	PG9 THREADED PLUG W/ O-RING	1
A	-	CONNECT RING TERMINAL UNDER SCREW & TORQUE TO 10±2 INCH-LBS	1
B	-	TORQUE TO 18±2 INCH-LBS	3
C	-	TORQUE TO 15±2 INCH-LBS	1
D	-	BACK TERMINAL NUT W/ WRENCH & TORQUE TO 15±2 INCH-LBS	1
E	-	APPLY MEDIUM STRENGTH THREAD LOCKING COMPOUND & TORQUE TO 20±2 INCH-LBS	1
F	-	TORQUE TO 100 - 120 INCH-LBS	2

SureFly
Granbury, Texas

SIM6C HARDWARE KIT

SCALE: 1:2.5	MATERIAL: N/A	FINISH: N/A
DIMENSIONS IN INCHES UNLESS OTHERWISE SPECIFIED		DRAWN BY: R. CONDY
		DATE: 05/21/2018
TOLERANCES:		
ANGLES ±1°	0.X ±0.050	0.XX ±0.030
	0.XXX ±0.010	
SHEET: 1/1	PART NO: SIM6C-HW	REV: B